



LIGHTING • FIRE & CO DETECTION



RADIO FREQUENCY FAST FIX MAINS HEAT & CO DETECTOR

WITH 10 YEAR RECHARGEABLE LITHIUM BATTERY

FEATURES

- Contains both a heat sensor & a Carbon Monoxide sensor
- Interconnect up to 20 wireless detectors
- 10yr Rechargeable Lithium Battery Backup
- Loud 85dB alarm
- Fast Fix base included
- Insect proof
- Test function and hush feature
- Tamper proof
- Compatible with Hispec Control Unit HSSA/CU/RF10-PRO

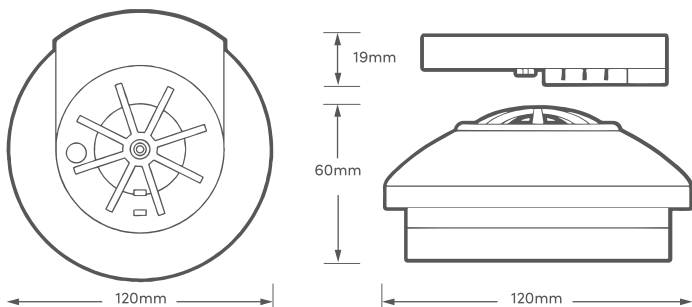

FAST FIX RF PRO



TECHNICAL INFORMATION

Scheme Rating:	D1
Detection Type:	Heat & CO Sensitive
Heat Sensor:	Thermistor Class A1 detection – Alarm is triggered at 60°C
Carbon Monoxide Sensor:	Electrochemical
Power Source:	220-240v
Battery Backup:	Rechargeable Lithium Battery with 10 year life
Alarm Sound Level:	86dB at 3 metres
Operating Temp:	0°C ~ 40°C
Carbon Monoxide Level (time to alarm):	50ppm (60-90 mins) 100ppm (10-40 mins) 300ppm (<3 mins)
Radio Frequency Range:	Up to 80m in open areas & 30m indoors
Weight:	158g
Approvals:	BS EN50291-1:2018 BS 5446-2:2003

Product Code: HSSA/HCO/RF10-PRO



hispec.co.uk

